

Programmable Temperature Controller

MTC-P Series

User manual

Please read this manual carefully and keep this manual for future use

General Specifications

- MTC-P series programmable temperature controller, 4 digits LED display, with bar graphic display, 0.2% accuracy, 0.1 resolution for thermocouple and Pt100 input signal, 0.001 resolution for analog input signal, auto/manual control bumpless transfer
- Maximum 4 different programs, each program with 8 segments, 4 program can be linked together as 1 program with 32 segments
- Maximum output power is configurable for each segment
- System time unit is switchable between hour, minute and second
- Easy monitoring on current running segment and program execution time period
- The program can start from process value or from 0
- The program can be triggered or terminated by front key or start running automatically after power on and controller has the power failure restore function
- When program finished, controller can repeat the preset program again or stop operating completely
- Guaranteed soak function
- segment ending alarm, program ending alarm, program running alarm segment ending alarm delay function
- RS-485 optional, master/slave communication mode optional
- Please make sure the wiring is correct before power on, the wiring diagram is on the size of the controller for easy reference during the wiring, make sure you are clear on the output type whether it is Relay, SSR drive or 4-20mA
- Controller can switch freely between thermocouple or RTD input signals for analog inputs, need to specify before order
- The factory default control action is OUT1 for reverse control (heating) customer can set OUT1 as direct control (cooling)
- Factory default control mode is P.I.D mode
- When I=0, d=0, the control mode set as time proportional mode, proportional value is rSt1, control cycle is Cyt1, the output decrease when rSt1 decrease under heating mode the output increase when rSt1 decrease under cooling control mode

1: Dimensions

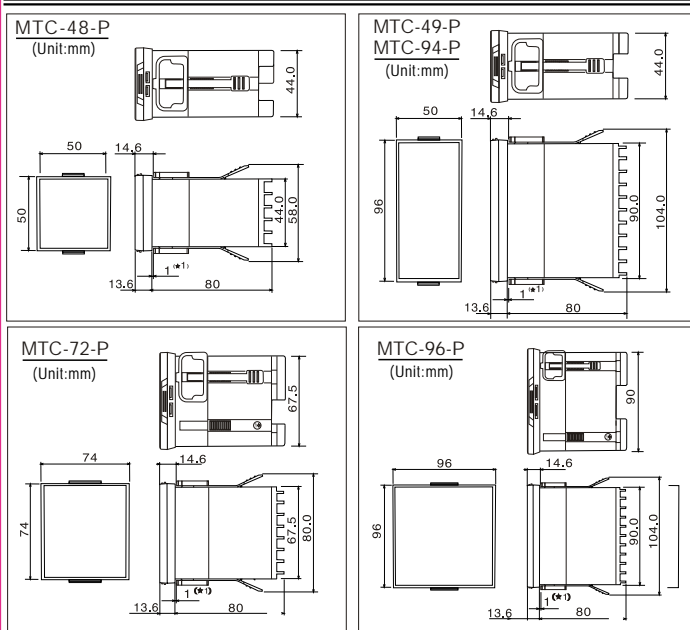

2: Ordering information

MTC-

	P						
1	2	3	4	5	6	7	8

1: Size Information

- 48:** 48mm(Width)*48mm(Height)
- 49:** 48mm(Width)*96mm(Height)
- 72:** 72mm(Width)*72mm(Height)
- 96:** 96mm(Width)*96mm(Height)
- 94:** 96mm(Width)*48mm(Height)

2: Version Code

- P:** Programmable temperature controller also known as Ramp and soak controller

3: Output

- | | |
|---------------------|-------------------|
| R: Relay | 5: 0-5VDC |
| V: SSR drive | 6: 0-10VDC |
| D: 4-20mA | 7: 1-5VDC |
| 2: 0-20mA | |

4: Alarm options

- 1:** 1 alarm
- 2:** 2 alarms
- 3:** 3 alarms

5: Power supply

- 96:** 85~265VAC

6: Re-transmission

- N:** Without re-transmission
- P42:** PV re-transmission as 4-20mA
- P005:** PV re-transmission as 0-5VDC
- P010:** PV re-transmission as 0-10VDC
- S42:** SV re-transmission as 4-20mA
- S005:** SV re-transmission as 0-5VDC
- S010:** SV re-transmission as 0-10VDC

7: Communication

- N:** Without communication
- K:** RS-485 Modbus RTU

8: Auxiliary Power supply

- N:** Without auxiliary power supply
- 24:** 24VDC

Remark: not all options are available at the same time. some of function share the same terminals, so various functions may create conflicts with each other, consult our sales team before order

3: Wiring diagram

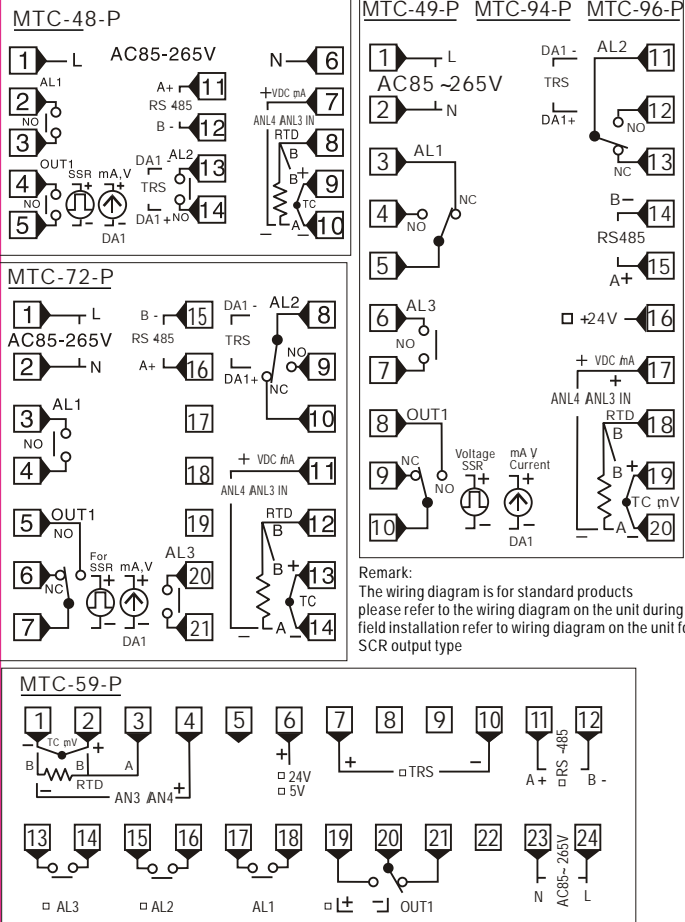

4: Panel discription

4.1 Panel discription

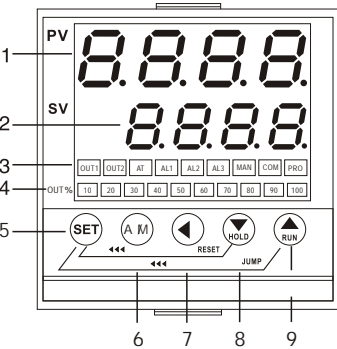

- PV, indicate process value
- SV, indicate setting value
- OUT 1: Output 1 indicator
 OUT2: Output 2 indicator
 AT: Auto-tuning indicator
 AL1: Alarm 1 indicator
 AL2: Alarm 2 indicator
 AL3: Alarm 3 indicator
 Man: manual control indicator
 COM: communication indicator
 PRG: Programm execution indicator
 Bar Graphic display
- SET key
- A/M, auto/manual control switch key
- ◀: Shift key(function key)
- ▼: Decrease, program pause key
- ▲: Increase, program active key

4.2 Operation key description

- Program active(RUN):** Press increase key for 3 second to active the program check PRO indicator, when it is flashing, program activated confirmed
- Program pause(HOLD):** Press decrease/HOLD key for more than 3 seconds during program is running to put the program on hold status, PRO indicator stop flashing and keep lighting
- Program jumping(JUMP):** Press incrise/Run key and SET key at the same time during the program is running, the program goes to next segment(Jump to next segment)
- Program reset(RESET):** Press decrease key and SET key at the same time, the program reset and PRO indicator went black out

4.3 Status when program ends

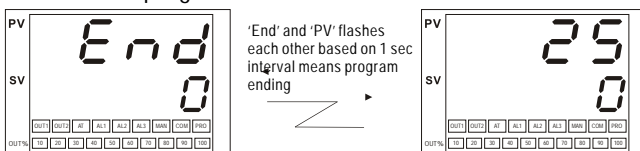

5. SETTING

5 1 Goes to different programming level

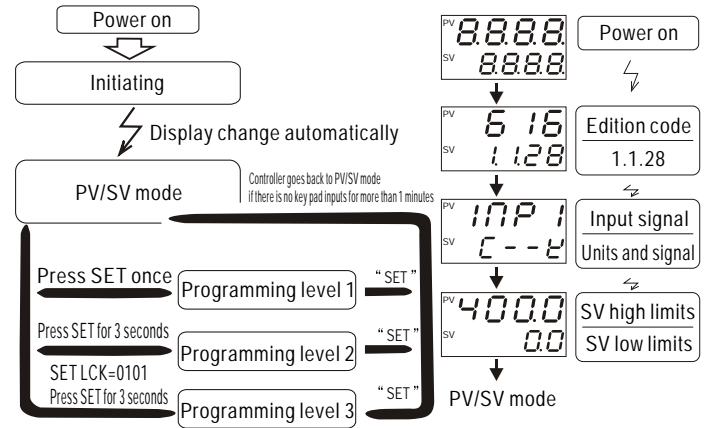

Symbol	E1	E2	E1	E2	J1	J2	N	ū
Input signal	K	K	E	E	J	J	N	Wu3_Re25
Range	400 °C	1300 °C	300 °C	600 °C	400 °C	800 °C	1300 °C	2000 °C

Symbol	S	t	r	b	AN4	AN3	AN2	AN1	PL1	PL2
Input signal	S	T	R	B	2-10VDC 1-5VDC 4-20mA	0-10VDC 0-5VDC 0-20mA	0-50mV	0-20mV	P1100	P1100
Range	1600 °C	400 °C	1700 °C	1800 °C					-199.9-200.0C	-200-800°C

5 2 Change AL1 value For example, change AL1 from 0 to 200°C

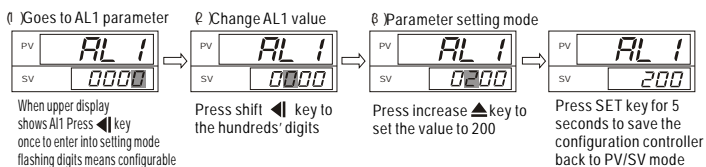

Remark
 Press decrease or increase once the value will increase or decrease by 1
 The value will decrease or increase continuously if keep pressing up or down key
 A/M key can be used to save the configuration made to different parameters
 * Press once can save the modification and exit from the menu
 * Press SET key for more than 3 seconds can save and exit from parameter menu no matter where you are

6 Programming Level

6 1 Programming level 1

6 1 1 General parameter under programming level 1

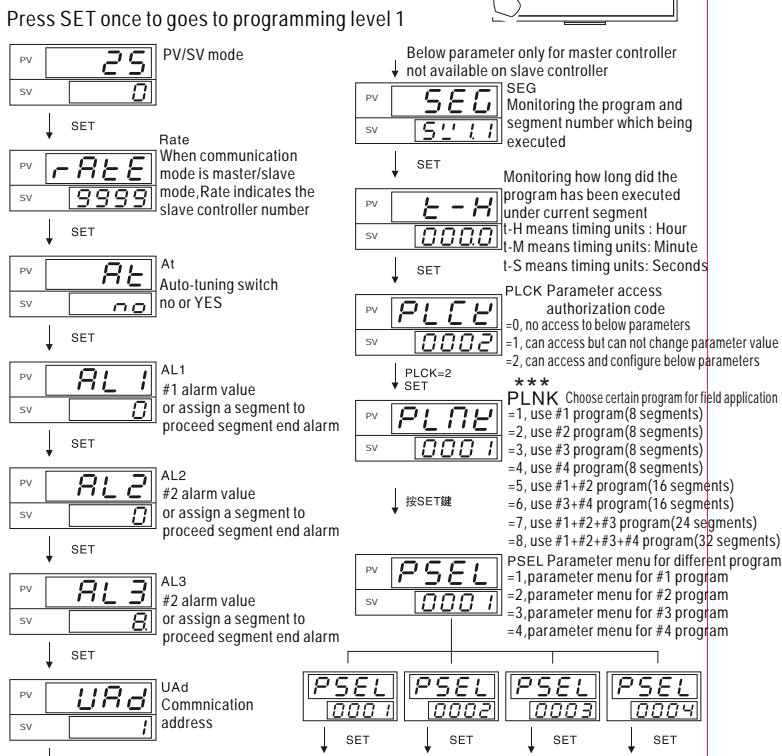

To next page

6 2 Typical application

Suppose we need a program with 5 segments, using #1 program for the application, check below curve, the maximum output ratio restricted to 80% at segment 4 to avoid damage.

system timing unit: hours

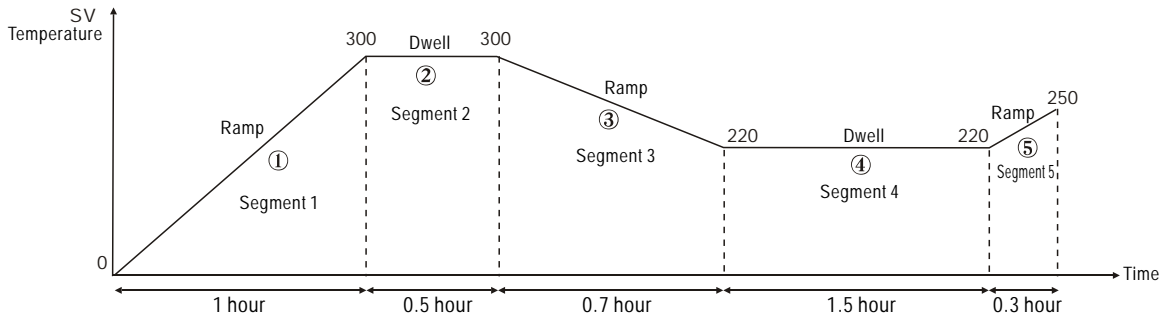

How to create a program like above figure

PV	25
SV	0

PV/SV mode

Press SET until you see PLCK

PV	PLCK
SV	0002

SET PLCK=2 to access to program configuration menu

PV	PLNK
SV	0001

SET PLNK=1 to use the #1 program for the application

PV	PSEL
SV	0001

SET PSEL=1 goes to parameter menu for #1 program

PV	SV 1.1
SV	300

Set the SV for #1 segment at 300C

SET

PV	tr 1.1
SV	1.0

Set the ramp time for #1 segment at 1 hour

PV	ot 1.1
SV	100.0

Maximum output for #1 segment is 100%

PV	SV 1.2
SV	300

Set the SV for #2 segment at 300

PV	tr 1.2
SV	0.5

Dwell time for #2 segment at 0.5 hour

SET

PV	ot 1.2
SV	100.0

Maximum output for #2 segment is 100%

PV	SV 1.3
SV	220

Set the SV for #3 segment at 220 C

PV	tr 1.3
SV	0.7

Ramp time for #3 segment is 0.7 hour

PV	ot 1.3
SV	100.0

Maximum output for #3 segment is 100%

SET

PV	SV 1.4
SV	220

Set the SV for #4 segment at 220 C

PV	tr 1.4
SV	1.5

Dwell time for #4 segment at 1.5 hour

PV	ot 1.4
SV	80.0

Maximum output for #4 segment is 80%

PV	SV 1.5
SV	250

Set the SV for #5 segment at 250 C

SET

PV	tr 1.5
SV	0.3

Ramp time for #5 segment is 0.3 hour

PV	ot 1.5
SV	100.0

Maximum output for #5 segment is 100%

PV	SV 1.6
SV	888.8

SET SV as any random value for #6 segment

PV	tr 1.6
SV	888.8

SET any random value for time of #6 segment

SET

PV	ot 1.6
SV	0.0

SET maximum output as 0.0% for #6 segment

Press SET key for 3 seconds or light press A/M key to save the configuration and exit from the programming menu

PV	25
SV	0

PV/SV mode

6 3 Program automatically terminated

SET the maximum output menu as 0.0% at certain segment if a program less than 8 segments

and program ending when it comes to the last segment. in above case, the program only have 5 segments, then set the maximum output for #6 segment as 0.0%, program ends after 5 segments.

6 4 Program automatically jumping

If a program needs to skip on certain segments, set the segment time as 0.0, when program runs to the segment where the time has been set as 0.0, it will go to next segment automatically, for example, in a program where we want to skip on segment 4, then SET the time for segment 4 as "0.0", then program automatically goes to segment 5 from segment 3.

6 2 Programming level 2

Refer to right figure, press SET key for 3 seconds to enter into programming level 2, below parameter shows one by one on the fixed sequence

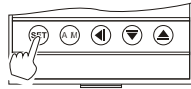

Parameter Notation	Parameter description	Range	Default value	Remark
P1	Proportional band for out1	0.0~200.0	20.0	Proportional band for output 1(SEP P=3.0 for analog input signal) unit is degree, when P1=0, controller works as ON/OFF controller
I1	Integral time for out 1	0-3600 Sec	210	Integral time for output 1, when I1=0, integral action disabled integral action gets more sensitive when I1 gets bigger, but fluctuation is more expected
D1	Derivative time for out 1	0-3600 Sec	30	Derivative time for output 1, when D1=0, the derivative action disabled derivative action gets more sensitive when D1 gets bigger, but fluctuation is more expected
ATVL	Auto tuning offset value(ATVL)	0-199 C	0	Set ATVL to prevent overshoot occurred during autotuning process.
CYCL	Control cycle time for out 1	0 to 999 Sec	20	Control cycle time for out 1 Set as 20 S for relay output, 2 S for SSR drive output
HYS1	Control Hysteresis For out1	0.0 to 100.0	2.0	When P1=0.0, OUT1 is on/off control In heating application PV>SV OUT1 terminated In cooling application: PV>SV+HYS1 OUT1 activated PV<SV OUT1 terminated
rSE1	Proportional reset For out1	30 to 30	5.0	Proportional reset for overshoot protection only for out1 output. (Auto set after auto-tuning)
OPL	Output lower limit	0.0 to 100.0%	0.0	To set the output lower limit for out 1
OPH	Output higher limit	0.0 to 100.0%	100.0	To set the output higher limit for out 1
LCK	Access protection parameter	0000 0255	0	LCK=0000: all parameters are configurable LCK=0001: only SV value configurable LCK=0010: configurable on SV and parameters under programming level 1 LCK=0011: can not configure all parameters LCK=0101: all parameters are configurable, accessible to programming level 3 LCK=0201: all parameters are configurable, accessible to programming level 4

6 3 Programming level 3

6 3 1 How to access to programming level 3

- Refer to 6.2 instruction and goes to programming level 2, SET LCK=0101 and press SET for 3 seconds to exit to PV/SV mode
- Refer to figure at right, Press SET and shift key at the same time for 3 seconds to access to programming level 3 below parameters will show one by one based on below sequence

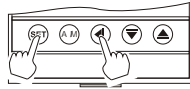

Parameter Notation	Parameter description	Range	Default value	Remark
INP1	Input signal selection			
	Input signal notation	E1 E2 E1 E2 J1 J2 N U		
	Description	K K E E J J N Wu3_Re25		
	Range	400.0 °C 1300 °C 300.0 °C 600 °C 400.0 °C 800 °C 1300 °C 2000 °C		
	Input signal notation	S E r b AN1 AN2 AN3 AN4 PE1 PE2		
	Description	S T R B 2..10VDC 0..10VDC 1..5VDC 0..5VDC 4..20mA 0..20mA 0..50mV 0..20mV P1100 P1100		
	Range	1600 °C 400.0 °C 1700 °C 1800 °C -2000 °C -2000 °C -199.9 ~ 200.0 °C -200 ~ 800 °C		
	Remark 1: User can select thermocouple or Pt100 via front key			
	Remark 2: Analog input has to be specified before order except 0-20mV and 0-50mV			
DP	Decimal point for analog input	0 1 2 3	0	0: No decimal point 1: 1 decimal point 2: 2 decimal point 3: 3 decimal point only applicable for analog input
LSPL	SV lower limit	-1999 to 9999	0	Setting value lower limit Or to define the lower limit temperature for Re-transmission function
USPL	SV higher limit	-1999 to 9999	400	Setting value higher limit Or to define the higher limit temperature for Re-transmission function
UNIT	Display unit	0 1 2	0	0: Celsius 1: Fahrenheit 2: Without Unit
P105	PV Bias value	199 to 199	0.0	To compensate the measuring error from the sensors
P1FE	Sampling rate	0 to 30	25	When value gets smaller, the response to the sensor is more sensitive but can expect some fluctuation, when value gets bigger, it will have reverse effects
ANL1	Analog input lower limit display value	-199~9999	0	For example, the display value is ANL1 when input is 4mA for 4-20mA range
ANH1	Analog input higher limit display value	-1999~9999	2000	For example, the display value is ANH1 when input is 20mA for 4-20mA range
ALD1	Alarm mode for #1 alarm	00 to 18	11	To define the alarm mode for #1 alarm refer to alarm mode figure for alarm mode description
AH1	Alarm hysteresis for #1 alarm	0.0 to 100.0	1.0	Alarm hysteresis value for #1 alarm High alarm(lower side hysteresis) Low alarm(higher side hysteresis)
ALD2	Alarm mode for #2 alarm	00 to 18	10	To define the alarm mode for #2 alarm refer to alarm mode figure for alarm mode description
AH2	Alarm hysteresis for #2 alarm	0.0 to 100.0	1.0	Alarm hysteresis value for #2 alarm High alarm(lower side hysteresis) Low alarm(higher side hysteresis)
ALD3	Alarm mode for #3 alarm	00 to 18	10	To define the alarm mode for #3 alarm refer to alarm mode figure for alarm mode description
AH3	Alarm hysteresis for #3 alarm	0.0 to 100.0	1.0	Alarm hysteresis value for #3 alarm High alarm(lower side hysteresis) Low alarm(higher side hysteresis)
OUT	Control action	0 or 1	0	0: Reverse control(heating) 1: Direct control(cooling)
ALT	AL1 Program ending alarm delay time	0 9999 Seconds	0	0: When value=0, the alarm output right after program end Other value from 1-9999 seconds Program end alarm output delay certain (from 1-9999 seconds) then output
WAIT	Wait	0.0~100.0 Celsius	0	0: Disable program holding function Other value: temperature range to active the program holding function
PUNT	PUNT System time units	0 1 2	0	0: Hour (0.0~999.9 Hour) 1: Minutes(0.0~999.9 Minutes) 2: Second(0~9999 Seconds)

Parameter Notation	Parameter description	Range	Default value	Remark
P-F	Temperature where the program starts to run	0 1	1	0: Program starts to run from 0 1: Program starts to run from process value
ADDR	Communication address	0 1 2 7	1	To configure the address of controller in communication mode
BAUD	Communication rate	0 1 2 3	2	bAUD=0 Rate=2.4K bAUD=2 Rate=9.6K bAUD=1 Rate=4.8K bAUD=3 Rate=19.2K

* Alarm mode(ALD=00~18)

- 10: No alarm output
11: Deviation high alarm
12: Deviation low alarm
13: Deviation high/low alarm
14: Deviation band alarm
15: Process high alarm
16: Process low alarm
17: Program execution alarm
18: Program ending alarm
- 00: No alarm output
01: Deviation high alarm with alarm standby function
02: Deviation low alarm with alarm standby function
03: Deviation high/low alarm with alarm standby function
04: Deviation band alarm with alarm standby function
05: Process high alarm with alarm standby function
06: Process low alarm with alarm standby function
07: Segment ending alarm

6 3 2 Alarm mode specification

Code	ALD	Specification(Example for alarm 1)
N	10 or 00	No alarm
A	11	Deviation high alarm AL1 0: LOW SV AH1 Alarm ON HIGH SV+AL1 AL1<0: LOW SV+AL1 SV HIGH
B	12	Deviation low alarm AL1 0: LOW SV AH1 Alarm ON HIGH SV+AL1 AL1<0: LOW SV+AL1 SV HIGH
C	13	Deviation high/low alarm AL1 0: LOW SV-AL1 SV AH1 Alarm ON HIGH SV+AL1 AL1<0: LOW SV+AL1 SV HIGH
D	14	Deviation band alarm AL1 0: LOW SV-AL1 SV AH1 Alarm ON HIGH SV+AL1 AL1<0: LOW SV+AL1 SV HIGH
H	15	Process high alarm AL1 0: LOW SV AH1 Alarm ON HIGH SV+AL1 AL1<0: LOW SV+AL1 SV HIGH
J	16	Process low alarm AL1 0: LOW SV AH1 Alarm ON HIGH SV+AL1 AL1<0: LOW SV+AL1 SV HIGH
E	01	Deviation high alarm with hold action AL1 0: LOW SV AH1 Alarm ON HIGH SV+AL1 AL1<0: LOW SV+AL1 SV HIGH
F	02	Deviation low alarm with hold action AL1 0: LOW SV AH1 Alarm ON HIGH SV+AL1 AL1<0: LOW SV+AL1 SV HIGH
G	03	Deviation high/low alarm with hold action AL1 0: LOW SV-AL1 SV AH1 Alarm ON HIGH SV+AL1 AL1<0: LOW SV+AL1 SV HIGH
M	04	Deviation band alarm with hold action AL1 0: LOW SV-AL1 SV AH1 Alarm ON HIGH SV+AL1 AL1<0: LOW SV+AL1 SV HIGH

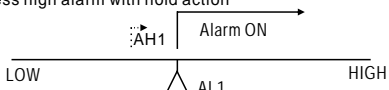
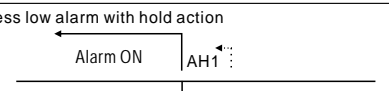
Code	ALd□	Specification(Take alarm 1 as example)
K	05	Process high alarm with hold action 
L	06	Process low alarm with hold action 
2	07	Segment ending alarm
3	17	Program execution alarm
4	18	Program ending alarm

Remark: "Alarm standby" function means if the alarm condition meets while controller just power on the alarm will not output, when temperature goes out to the alarm range and falls back to alarm range again, the alarm will output Alarm mode apply to all three alarms, alarm 1, alarm 2 and alarm 3.

6.3.3 Various alarm for program control

Segment ending alarm: When ALd=07, the alarm is defined as segment ends alarm AL(AL1, AL2, AL3) value means when program comes to the certain segment, the alarm will output

For example, When ALd1=07, AL1=2(or 0.2), means when program finish segment 2. the alarm will go off and remind operator that the segment 2 is finished.

Program ending alarm, When ALd01=17, the alarm is defined as program ends alarm, When program ends, the alarm will go off.

Program execution alarm, When ALd01=18, the alarm will go off when program starts

6 4 Programming level 4

6 4 1 How to access to programming level 4

- Follow instruction in 6.2 to goes to programming level 2, change LCK value to 0201 then press SET key for 3 seconds to save the change
- Refer to image at right, Press SET and ◀ at the same time for 3 seconds to goes to programming level 4, below parameter will display one by one



Parameter Notation	Parameter description	Range	Factory default	Remark
ConF	ConF Communication function setting	0 1 2	0	ConF =0: Turn off communication ConF =1: Turn on communication ConF =2: Turn on Master/Slave communication mode
trSF	TrSF Re-transmission setting	0, 1	0	TrSF=0: Re-transmission on the process value trSF=1: Re-transmission on the setting value
PcRL	PcRL Master/Slave communication mode configuration	0, 1	1	PcRL=0: Define controller as slave controller PcRL=1: Define controller as master controller
ot1	Ot1 Analog output configuration	0, 1	0	Ot1=0: Define analog output as re-transmission output Ot1=1: Define analog output as PID control output
AUTO	AUTO Auto/manual control configuration	0, 1	0	AUTO =0 : Disable auto/manual switch AUTO =1 : Enable auto/manual switch
PrON	PrON How programs starts to run after power on and after power failure	0, 1, 2	0	PrON=0: Program resets right after power on, press start key to active the program manually. PrON=1: Program starts to run at the point before power cut off(apply in power failure situation) PrON=2: Program resets right after power on then runs the program automatically
PrEP	PrEP Program repeat mode configuration	0, 1	0	PrEP =0: Program doesn't repeat after program ends PrEP =1: Program repeat from segment 1 after one complete circle

7: Panel discription

Manual control works only after the program starts to run

All controllers except 48mm*48mm with auto/manual (A/M) transfer key

Example: Following is an example of manual setting to 70% output.

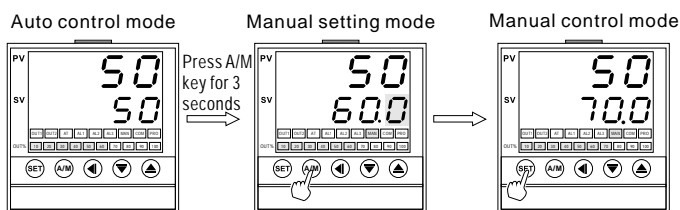

MAN lamp is turns off in Auto control mode.

Press A/M key for 3 seconds to manual setting mode. In manual setting mode, MAN lamp light up, The digit which flashing is settable.

Pressing the UP key increase numerals, and pressing the DOWN key decrease numerals. Press SET key after set value to 70.0.

- **In manual control mode ,press A/M key for 3 seconds to auto control mode.
- **Power-on Manual function can be selected. Pko in level2 for initial output value.
- **A/M key can also be used for SAVE and EXIT key.

8 AUTO-TUNING

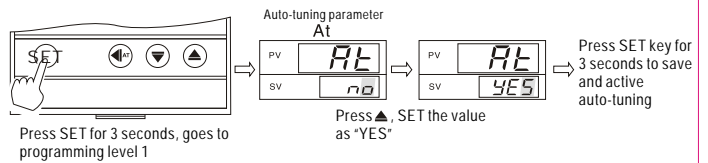

Master controller: the SV value for the auto-tuning process is the SV for the first segment

Slave controller: the auto-tuning for the slave controller must be activated after the master controller, the setting value is related to master controller

9 Master and Slave Communication Mode

- Master controller: Act as master controller to control slave controller
- Slave controller: controlled by master controller, the SV value was given by master controller
SV and Rate parameter for slave controller
SV for slave controller, $SV = (\text{Rate} \div 9999) \times \text{SV of master controller}$

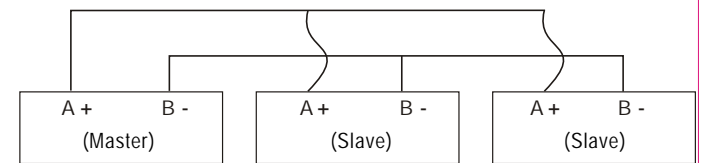

SV for master and slave controller

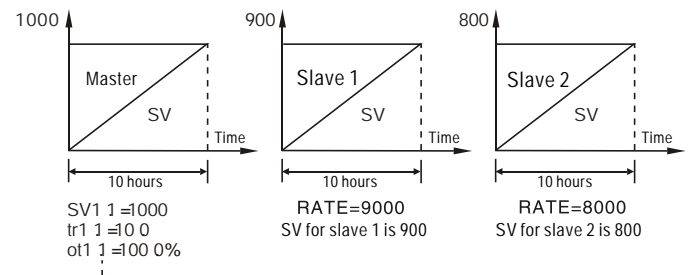

10 RS 485 Communication

- Support Modbus-RTU protocol, support 03 read command, 06 and 10 write command
- Communication mode: single-master Rs485 asynchronous serial communication baud rate: 2400, 4800,9600,19200(9600 baud rate is factory default value)
- The maximum write command for the controller is 36 at once, maximum read command is 37 at once for the read command

11 Input Ranges

Input type	Code	Input type	Code
K1	0 0 to 200 0 °C	2	D2
	0 0 to 400 0 °C	2	D4
	0 to 400 °C	K	A4
	0 to 600 °C	K	A6
K2	0 to 1300 °C	K	B3
	0 0 to 200 0 °C	3	D2
	0 0 to 300 0 °C	3	D3
E1	0 to 200 °C	E	A2
	0 to 400 °C	E	A4
	0 to 600 °C	E	A6
J1	0 0 to 300 0 °C	1	D3
	0 0 to 400 0 °C	1	D4
J2	0 to 300 °C	J	A3
	0 to 400 °C	J	A4
	0 to 800 °C	J	A8
T	0 0 to 300 0 °C	T	D3
	0 0 to 400 0 °C	T	D4
S	+ 0 to 1600 °C	S	B6
R	0 to 1700 °C	R	B7
B	200 to 1800 °C	B	B8
N	0 to 1300 °C	N	B3
Wu3_Re25	600 to 2000 °C	W	B0
Pt1 (Pt100)	0.0 to 50.0 °C	P	06
	0.0 to 100.0 °C	P	07
	0.0 to 200.0 °C	P	08
	-50.0 to 100.0 °C	P	13
Pt2 (Pt100)	-199.9 to +200.0 °C	P	02
	0 to 100 °C	D	A1
	0 to 200 °C	D	A2
	0 to 400 °C	D	A4
	0 to 800 °C	D	A8
	-100 to 200 °C	D	C2
	200 to 400 °C	D	C4
	200 to 600 °C	D	C6
200 to 800 °C	D	C8	
Input type		Code	
AN1 0 to 20mV	-1999 to 9999	V	01
AN2 0 to 50mV	-1999 to 9999	V	02
AN3 0 to 5VDC	-1999 to 9999	V	03
AN3 0 to 10VDC	-1999 to 9999	V	04
AN4 1 to 5VDC	-1999 to 9999	V	08
AN4 2 to 10VDC	-1999 to 9999	V	09
AN4 4 to 20mA	-1999 to 9999	A	03
AN3 0 to 20mA		A	02
AN3 0 to 10mA		A	01

Remark: when input signal is S thermocouple, the accuracy is not guaranteed at range 0-100 celcius

- User can select thermocouple and Pt100 using front key
- Analog input signal has to be specified before order expect 0-20mA and 0-50mA